



SUBMITTAL/TECHNICAL DATA SHEET

Door is fabricated from 16 gauge, galvanized steel with a white prime coat finish and 1" thick rigid foam insulation.

Frame is fabricated from 16 gauge, galvanized steel with a white prime coat finish and provided with bolt holes.

Hinge is concealed and operates completely out of sight, so that only the door and frame are visible.

Exterior latch is a cylinder lock that features a knurled knob or key operation.

Finish is a white prime coat suitable for painting.

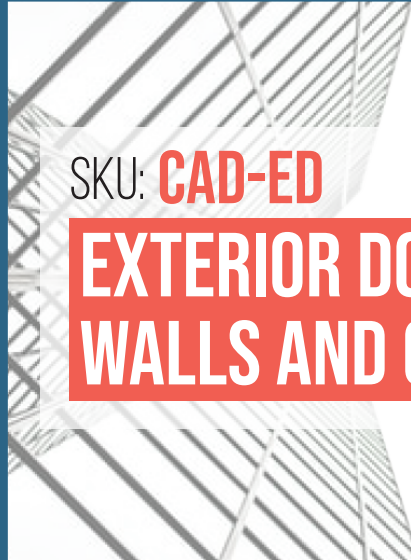

SKU: **CAD-ED**

EXTERIOR DOOR FOR WALLS AND CEILINGS



DIMENSIONS AND APPEARANCE

>> [CLICK TO VIEW ADDITIONAL DETAILS AND PRICING](#) <<

GUIDE SPECIFICATION

Access door frame shall be fabricated from 16 gauge galvanized steel with a white prime coat finish and provided with bolt holes. Access door panel shall be fabricated from 16 gauge galvanized steel with a white prime coat finish. Door shall be filled with 1" thick, rigid foam insulation and neoprene gasket on four sides. Access door shall have a concealed hinge with exterior latching cylinder lock that features a knurled knob or key operation. Finish shall be a white prime coat suitable for painting.

DOOR SIZE (W X H)	CEILING OPENING (Minimum Required)	LATCHES	WEIGHT
ED 8" x 8"	8-3/8" x 8-3/8"	1	5 lbs.
ED 12" x 12"	12-3/8" x 12-3/8"	1	15 lbs.
ED 14" x 14"	14-3/8" x 14-3/8"	1	17 lbs.
ED 18" x 18"	18-3/8" x 18-3/8"	1	20 lbs.
ED 22" x 30"	22-3/8" x 30-3/8"	2	35 lbs.

DOOR SIZE (W X H)	CEILING OPENING (Minimum Required)	LATCHES	WEIGHT
ED 24" x 24"	24-3/8" x 24-3/8"	1	28 lbs.
ED 24" x 36"	24-3/8" x 36-3/8"	2	40 lbs.
ED 30" x 30"	30-3/8" x 30-3/8"	2	38 lbs.
ED 36" x 36"	36-3/8" x 36-3/8"	2	50 lbs.
ED 36" x 48"	36-3/8" x 48-3/8"	2	81 lbs.

MODEL NUMBER AND OPTIONS SELECTION

BASE MODEL NUMBER

- ED Exterior Door for Walls and Ceilings

SUFFIX OPTIONS

- GB Galvanized Drywall Bead
- SS Stainless Steel Construction (Type 304 No. 4 Satin Finish)

For a complete list of options visit www.CaliforniaAccessDoors.com

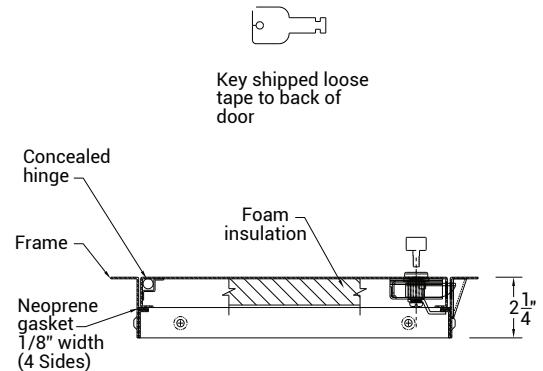
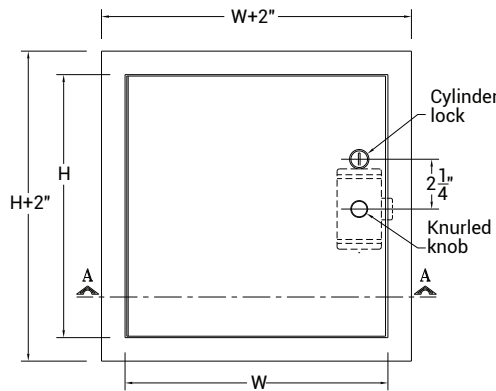

PROJECT DATA

Custom Sizes Available - Fast!

PROJECT NAME :	QTY	W	H	OPTIONS
ARCHITECT :				
DEALER :				
CONTRACTOR :				
LOCATION :	SPECIAL INSTRUCTIONS :			
DATE :				
TAGGING INSTRUCTIONS :	SUBMITTAL APPROVAL : (signature or stamp)			

Scan or Click



To view Pricing and Additional Product Info.

TELEPHONE: 1-800-656-1095
FAX: 1-888-828-6021



PO BOX 7775 PMB
76520, SAN FRANCISCO,
CALIFORNIA 94120-7775
US



WEBSITE: www.CaliforniaAccessDoors.com
E-MAIL: info@CaliforniaAccessDoors.com